



NEC



DIGITAL TELEPHONE USER GUIDE

Xen IPK Digital Telephones

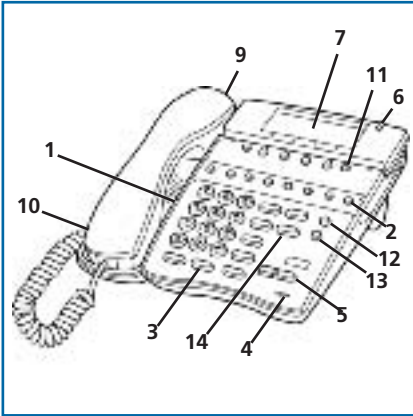

Dterm Series / 8 line display

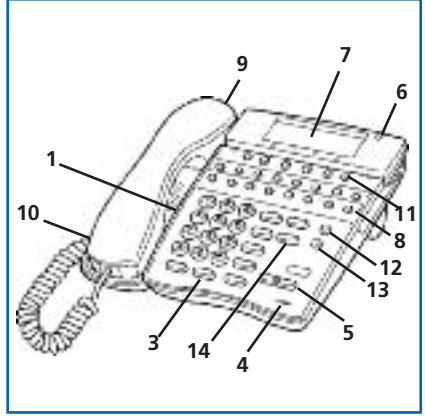

Dterm Series / 16 line (LED) display

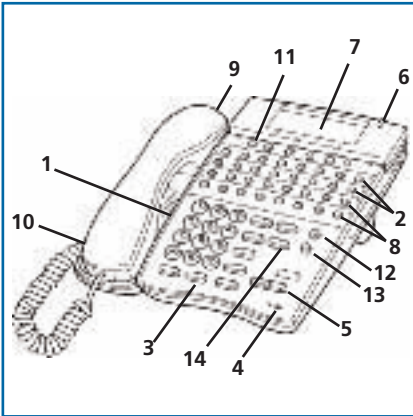

Dterm Series / 16 line display with 16 DSS/BLF One Touch Keys

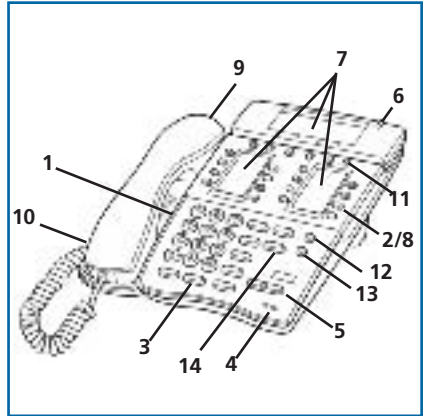

Dterm Series / 16 line (LCD) display

1. Speaker
2. Line Keys/Feature Access Keys
3. Dial pad/Dedicated Function Keys
4. Microphone
5. Volume Control
6. Large LED
7. Alphanumeric Display (LCD)

8. One Touch Keys
9. Handset
10. Built-in Headset Jack
11. Softkeys
12. Directory Key (DIR)
13. Message Key (MSG)
14. Microphone Key (MIC)



Table of Contents

General Information	
Answering Calls	Pages 2 – 3
Making Calls	
Microphone Control	
Handsfree Calls	
Placing a call on Hold	Pages 4 - 6
Transferring Calls	
Conference	
Conference Bridge	
Call Park - System	
Station Busy/No Answer Options	Pages 6 - 9
Outside Call Dialling Options	Pages 9 - 10
Call Pickup	
Paging	
Background Music	
Call Forwarding	Pages 11 - 12
Call Forwarding Destination	
Customised Message	
Set Relocation	
Station Outgoing Lockout	
Account Code Entry	
Account Code Forced/Verified	Pages 13 - 14
DISA Password	
ACD/UCD	
Volume Control	
Programming	Pages 15 - 19
Quick Reference Guide	
Interactive Softkey Definitions	Pages 20 - 21

General Information

The following should be considered when reviewing this User Guide:

- Instructions are provided for the NEC Xen IPK digital telephones (Dterm Series i).
- All operational instructions assume Prime Line Pickup is assigned to intercom dial tone, Ringing Line Preference is assigned to all telephones, a Call Appearance and Call Arrival key has been assigned to all digital telephones and only a single tenant has been assigned in the system.
- All access codes listed are standard; some may vary based on system assignment. Please consult your authorised NEC Dealer for the access codes applicable to your system.
- Access to many features is based on system assignments. Not all features may be available from your telephone.
- Digital telephones are equipped with displays to provide useful call processing information such as digits dialled, recall indications, feature confirmation, etc. Xen IPK digital telephones also show features accessible by the soft keys.
- This document supports main software R3000 series.

LED Indications

Function	Lamp Status
Line Keys:	
Incoming Call	Rapid Flashing Red
Held Call - Your telephone	Slow Flashing Green
Held Call - Other telephone	Slow Flashing Red
Call in progress	
Your telephone	Steady Green
Other telephone	Steady Red
Hold recall	Intermittent Flashing Green
Large LED: (360° Visual Ring Indicator)	
Incoming calls (CO/PBX, DIT or ANA)	Rapid Flashing Green
Incoming intercom, TIE Line or DID Call	Rapid Flashing Red
Message from Attendant	Slow Flashing Green
Voice Mail Message	Slow Flashing Red
Feature Key:	
DND Set	Intermittent Flashing Red
Call Forward Set	Intermittent Flashing Red
Callback Request	Slow Flashing Red
Held Intercom Call	Conf LED Flashing Red
Microphone On	Mic LED Steady Red
Handset Muted	Mic LED Flashing Red

Answering Calls

Ringing Calls

- Lift Handset
- Converse

Note: When assigned the delayed ringing feature, incoming calls will first ring at a primary station. If the call is unanswered after a preprogrammed time interval, calls will also ring at the assigned secondary station.

Ringing Calls To A Call Arrival Key

- Lift handset
- Converse

Note 1: A Call Arrival key must be assigned to appear and ring at a Line Key/Feature Access Key.

Note 2: A Call Appearance key must be available to answer an incoming outside call.

Voice Announce Calls

- Ensure microphone (MIC) LED is lit
- Adjust **Speaker** volume \wedge or \vee as needed
- Respond handsfree

Note: The handset may be used at any time during the conversation

Camp-on (Call Waiting)

- Receive camp-on tone while on another call
- Replace handset to disconnect present call OR press **Hold** and press the **Hookswitch** to converse with second party.

Call Alert Notification

With a call in progress

- Receive Call Alert Notification
- Press **Hold**, converse with second party

Note 1: The second call may be placed on hold if the line appearance is assigned or if a Call Appearance key is available

Note 2: Press flashing Line Key, Call Appearance key or Conf key to return to the first call.

Making Calls

Internal Calls

- Lift handset
- Dial station number or **9** for the attendant (or reception)
OR press **Feature Access Key** or **One Touch Key** programmed for Direct Station Selection
- Voice announce after tone burst or wait for ringing call to be answered.

Note 1: When calling a digital telephone, dialling **1** after the station number will change ringing to voice or voice to ringing.

Note 2: To directly access a personal voice mailbox on the Xen Mail system, press **Message** or dial **7** after dialling the station number.

Outside Calls

- Lift handset
- Dial trunk access code i.e **0**
OR press idle **Outside Line Key**
- Dial telephone number
- Converse

Preset Dialling

- Dial the desired number
- Lift handset
- Converse

Last CO/PBX Number Redial

- Lift handset
- Press **Redial**
- Dial Last Number Redial code #
- Converse

Speed Dial – Using The Redial key

- Lift handset
- Press **Redial** and dial Speed Dial Memory Location:

(100 Speed Dial Mode)	Station Speed Dial	80-99
	System Speed Dial	00-79
(1000 Speed Dial Mode)	Station Speed Dial	*, 00-09
	System Speed Dial	000-999
- OR** press **Feature Access key** or **One Touch Key** programmed for Station Speed Dial
- Converse

Speed Dial – Using The Softkeys

- Press the **SYS.** or **STA.** Softkey
(System or Station Speed Dial respectively)
- Press the **UP** or **DOWN** softkey, repeatedly until the desired name/number is displayed.
- To search alphabetically (optional step):
 - Press the dial key showing the first letter of the name to be dialled
 - Continue to press this dial key until the desired letter is displayed
 - Press ***** to display the first match corresponding the chosen letter
- Lift handset to dial the displayed name/number

Hot Keypad

- Dial desired digits on keypad (system will automatically activate handsfree and dial)
- When dialled party answers
- Converse

Trunk Queuing

After dialling trunk access code or pressing a busy **Line Key** and receiving a line busy indication:

- Dial Trunk Queue set code **78**
- OR press **T.Q.** softkey
- Replace handset

Note: When a line is available, your telephone will ring: lift handset and place call.

Microphone Control

- Press **MIC** key OR press **MIC** softkey
or
- Press **Feature**
- Dial MIC On/Off code **1**

Note 1: Lit MIC LED indicates MIC on

Note 2: **MIC ON/OFF** key may be assigned to a **Feature Access Key** or **One Touch Key**

Note 3: If talking on handset rather than handsfree, the handset microphone will be muted and the MIC LED will flash.

Handsfree Calls

- Press **Speaker**, LED lights
- Ensure **MIC** LED is lit
- Place internal or outside call
- Converse
- Press **Speaker** to disconnect call

Note: The handset may be used at any time during the conversation. To resume handsfree operation or to monitor a call, press **Speaker** (LED lights) and replace handset.

Group Listening

With a call in progress via the handset/headset:

- Press **Speaker**, then the LED Lights
- Converse. Conversation is heard over the speaker and the handset/headset. Only the handset/headset may be used to respond.
- Press **Speaker** to cancel the Group Listening mode

Note: When switching from Group Listening mode to the **Handsfree Mode**, it is recommended that the Microphone be turned off.

Placing A Call On Hold

Non-Exclusive Hold

With a call in progress:

- Press **Hold**

Exclusive Hold

With a call in progress:

- Press **Feature**
- Press **Hold**

Note 1: To retrieve a held call, press the flashing **Line Key**, **Call Appearance Key** or **Conf key** (for internal calls).

Note 2: Call on Non-Exclusive Hold can be retrieved from any digital telephone with the held line appearance or **Call Appearance key**.

Note 3: After a preprogrammed time, the held call will recall to the originating station. Once in a recall condition, Exclusively Held calls can be retrieved from any station with the held line appearance or **Call Appearance key**.

Transferring Calls

Using Manual Dial

With a call in progress:

- Press **Transfer**
- Dial station number
- Announce call (optional)
- Replace handset

Note 1: If the called station is busy, replace handset to initiate a camp-on. Unanswered camp-ons and unscreened transfers will recall to the attendant telephone. After answering the recall, pressing **Feature 86** will transfer the call to the personal voice mailbox of the station number dialled.

Note 2: To return to the original party, press flashing **Line Key**, **Call Appearance key** or **Conf key**.

Using Direct Station Selection (DSS)

With a call in progress:

- Press **Transfer**
- Press programmed **DSS**
- Announce call (optional)
- Replace handset

Note 3: A **Feature Access Key** or **One Touch Key** may be assigned for DSS.

Note 4: To transfer a call directly to a personal voice mailbox, press **Message** or dial 7 after dialling the station number.

Conference

With a call in progress:

- Press **Conf**
- Place second call (internal or external)
- Announce conference
- Press **Conf** to establish conference

Note 1: Repeat above procedure to add an additional party. (Max 2 outside parties).

Note 2: An unsupervised conference may be established by pressing the **Conf** key again, after the conference has been established. The parties may continue to converse in private. Press the flashing **Conf** key to return to the conversation.

Conference Bridge

To make a call using a conference Bridge:

- Call a Conference Bridge extension.
- When the voice prompt is heard, enter the password and press #.
- Start the conference call.

Start a conference call from an incoming outside call using an Automated Attendant:

- Call an outside line that is answered by an Automated Attendant.
- Dial the extension of the Conference Bridge.
- When the voice prompt is heard, enter the password and press #.
- Start the conference call.

Start a conference call from an off-premise location:

- Call a line that is directed to the Conference Bridge.
- When the voice prompt is heard, enter the password and press #.
- Start the conference call.

Start a conference call from an incoming outside call using an Attendant:

- Call the Attendant and ask to be transferred to a Conference Bridge extension.
- Wait until the transfer is complete.
- When the voice prompt is heard, enter the password and press #.
- Start the conference call.

Note: Default passwords: Conference #1 = 0001
 Conference #2 = 0002

Call Park - System

Set

With a call in progress:

- Press **Transfer**
- Dial Call Park Set code **4***
- OR press **Park** softkey
- Dial Call Park location 0-9
- Replace handset

Retrieve

From any station:

- Lift handset
- Dial Call Park Retrieval code **4#**
- Dial Call Park Location 0-9
- Converse

Note: If the dialled Call Park location is busy, dial another Call Park location (0-9).

Station Busy/No Answer Options

Automatic Callback

Set

When calling a busy digital telephone:

- Dial Automatic Callback code **0**
- OR press **CBR** softkey
- Replace handset

Answer

When both telephones are idle originating telephone rings:

- Lift handset
- Call is placed automatically

Callback Request

Set

When calling a busy or unanswered digital telephone:

- Dial Callback Request code#
- OR press **T.O.** softkey
- Replace Handset

Answer

Receive display and/or **Feature** LED message indication:

- Lift handset
- Dial #; request originator is automatically called
- Repeat above procedure to respond to additional messages

Note: Callback messages are automatically cancelled once the originating station is called. Callback Request access code # must be assigned in system programming.

Tone Override

Set

When calling a busy digital telephone:

- Dial Tone Override code ***** to send tone
- OR press **T.O.** softkey
- Wait for signalled party to answer

Answer

With a call in progress:

- Receive tone override signal †
- Press **Hold**
- Converse with second party

†If handsfree, a visual indication only (*) will be provided on the telephone's display.

Note: An Override Tone will be sent each time * is pressed.

Station Busy/No Answer Options (Continued)

Step Call

When calling a busy telephone:

- Dial **2** to advance to the next station number in that 10's group
- OR press **MORE** then **STEP** softkeys

Voice Over Originate

When calling a busy telephone:

- Dial Voice Over code **6**
- Announce message

Answer

With a call in progress:

OR press **MORE** then **V.O.** softkeys

- Receive Voice Over announcement
- Press **Hold**
- Converse with Voice Over originator
- Press **Answer** key to alternate between parties

Whisper Page

With a call in progress:

- Receive Voice Over announcement
- Press **Feature**
- Dial **65**
- Converse with Voice Over originator while monitoring first call
- Press **Feature**
- Dial **65**
- Converse with first caller while monitoring Voice Over originator

Note: The Whisper Page Access Code may be assigned to a Feature Access Key or One Touch Key.

Outside Call Dialling Options

Save & Repeat

Save

With an originating outside call in progress:

- Press **Feature**
- Dial **9**; called number is stored
- Replace handset

Repeat

- Lift handset
- Press **Redial**
- Dial ******; stored number is dialled

Outside Call Dialling Options (Continued)

Store & Repeat

Store

With an outside call in progress:

- Press **Feature**
- Dial **7**
- Dial new phone number to be stored
- Press **Feature**
- Complete conversation and replace handset

Note: Store & Repeat and Save & Repeat features cannot be used simultaneously.

Repeat

- Lift handset
- Press **Redial**
- Dial *** * ***; stored number is dialled

Automatic Redial

After originating a busy or unanswered outside call:

- Press **Speaker**
- Replace handset
- Press **Feature**
- Press **Redial**

OR press **AUTO-RD** softkey

- Call is repeatedly dialled until answered, cancelled or the maximum number of redial attempts is reached
- Lift handset when the called party answers

Note 1: Press Speaker to cancel Automatic Redial.

Note 2: System programming determines waiting time and number of redial attempts.

Caller ID

Answer

Receive incoming ringing or transferred outside call:

- Review telephone display for calling party's name or number
- Answer call accordingly

Placing Caller ID Calls

- Press **Directory** (or **SCROLL Key**) repeatedly until desired number is displayed
- Lift handset to automatically dial displayed number
- Converse

Note 1: Caller ID will be displayed even when station is busy or in DND mode, allowing the user to identify the incoming call.

Note 2: The last 50 calls received with caller ID information are stored and are accessible with the **Directory** (or **SCROLL**) key.

Note 3: Least Cost Routing (LCR/ACR) is required to automatically dial Caller ID calls.

Note 4: Press lit **Line Key** to review calling party's name or number while the call is in progress.

Call Pick Up

Call Pick Up System

Upon hearing ringing at another telephone:

- Lift handset
- Dial Call Pickup code:
 - All Calls **68**
 - Outside Line **6***
 - Night Call Pickup **69**
- Converse

Paging

- Lift handset
- Dial paging code:

Internal

- All zones **51**
- Zone A **52**
- Zone B **53**
- Zone C **54**

External

- All int. & ext. **59**
- All zones **55**
- Zone A **56**
- Zone B **57**
- Zone C **58**

- Page
- Wait for Meet-Me Answer or replace handset

Meet-Me Answer

- Lift handset
- Dial Meet-Me Answer code:
 - Internal Page **5***
 - External Page **5#**
- Converse

Background Music

Set/Cancel

- Press **Feature**
- Dial BGM On/Off code **26**

Note: A BGM key may be assigned in system programming to set/cancel the Background Music feature.

Call Pick Up Direct

Upon hearing ringing or voice announcement at another telephone:

- Lift handset
- Dial Call Pickup Direct code **67**
- Dial station number of the telephone to be answered
- Converse

Call Forward All Calls (CF/A) Do Not Disturb (DND)

Set

- Press **Feature**
- Dial Call Forward All/DND set code **60**
- Select operation
 - **DND**: Press **Feature**
 - **Call Forward All**: Dial destination station number or voicemail and press **Feature**

Cancel

- Press **Feature**
- Dial Call Forward All/DND cancel code **69**
- Press **Feature**

Set/Cancel using Softkeys DND:

- Press **MORE** Softkey
- Press **DND** Softkey to toggle setting
- Press **Feature**
- CFA:**
 - Press **MORE** Softkey
 - Press **CFA** Softkey to toggle setting
 - Dial destination station number
 - Press **Speaker**

Note 1: The Feature LED will flash intermittently when your telephone is in CFA/DND.

Note 2: While set, Call Forward All will override Call Forward Busy/No Answer setting.

Note 3: If Call Forward All and Do Not Disturb are both set, the feature set last is activated.

Note 4: A CFA/DND key may be assigned in system programming to set/cancel this feature. When setting Call Forward All, a destination station number must be entered. A lit LED indicates that Call Forward All/Do Not Disturb is set.

Call Forward Busy/No Answer (B/NA)

Set

- Press **Speaker**
- Dial Call Forward B/NA set code **43**
- Dial destination station number or voicemail

Cancel

- Press **Speaker**
- Dial Call Forward cancel code **44**
- Press **Speaker**

Set/Cancel using Softkeys

- Press **MORE** Softkey
- Press **CF/BNA** Softkey to toggle setting
- Dial destination station number
- Press **Speaker**

Note 1: While set, Call Forward All will override Call Forward Busy/No Answer setting.

Note 2: A CF B/NA key may be assigned in system programming to set/cancel this feature. When setting Call Forward Busy/No Answer, a destination station number must be entered. A lit LED indicates that CF B/NA is set.

Call Forward Destination

From Destination Station

Set

- Press **Speaker**
- Dial Call Forward All Destination set code **47**
- Dial your station number or voicemail
- Dial destination station number
- Press **Speaker**

Cancel

- Press **Speaker**
- Dial Call Forward All Destination cancel code **48**
- Dial your station number
- Press **Speaker**

Customised Message

From display telephone:

- Press **Feature**
- Dial Customised Message code **70**
- Dial ***** to scroll through messages
- Dial **#** to select messages
- Dial return date and time if required (Month/Day, Hour/Minute, using 4-digit, 24 hour clock)
- Press **Feature**

Note: When your telephone is set for **Do Not Disturb**, other display telephones will receive your message upon calling your station.

Set Relocation

- Ask the Attendant to turn on the Set Relocation Mode.
- From the new location, press **Speaker**, then the LED lights.
- Dial Set Relocation code _____
- Dial **your** station number.
- Dial the Station Password (same as the Station Outgoing Lockout [Password] code).
- Hear the confirmation tone and then press **Speaker**.
- Inform the Attendant to turn **Set Relocation Mode** off.

Station Outgoing Lockout

Changing Lockout Code

- Press **Speaker**
- Dial Lockout Change access code _____
- Dial current Lockout code
- Dial new Lockout code
- Press **Speaker**

Note 1: By default, Lockout code is set at 0000000000 (10 zeros).

Note 2: When Lockout code is set for the first time, station is automatically restricted.

Note 3: Lockout code may be a maximum of 10 digits. If the new Lockout code is less than 10 digits, press the Speaker to re-enter.

Note 4: When set, Station Outgoing Lockout restricts all outgoing calls.

Set/Cancel Station Outgoing Lockout

- Press **Speaker**
- Dial Station Lockout
 - Set code _____
 - Cancel code _____
- Dial Lockout code
- Press **Speaker**

Account Code Entry

With an outside call in progress:

- Press **Feature**
- Dial **66**
- Dial Account Code
(16 digits maximum)
- Press **Feature**

With an outside call on hold:

- Dial Account Code Entry
Code _____
- Dial Account Code
(16 digits maximum)
- Retrieve held call

Note 1: The outside party will not hear digits being dialled.

Note 2: The Account Code Entry Code may be assigned to a **Feature Access Key** or **One Touch Key**.

Account Code Forced

To place an outside call:

- Lift handset
- Dial Forced Account Code access code _____
- Dial Forced Account Code _____ (up to 13 digits)
- Dial trunk access code i.e. 0 and outside number

Note: When calling from a station that is assigned the Account Code Forced / Verified feature, outgoing call will only be processed after the dialled Account Code is verified.

DISA Password

Setting Your DISA Password

- Lift handset
- Dial DISA Password set access code
- Dial your DISA ID code _____
- Dial your current DISA password _____ default 0000000000 (10 zeros)
- Dial your new DISA password _____
- Replace handset

Note 1: Password may be a maximum of 10 digits. If the new password is less than 10 digits, replace the handset to enter.

Note 2: It is recommended that your DISA password be 10 digits and be changed frequently to prevent unauthorised use.

ACD/UCD

Log On

- Press **Speaker**
- Dial access code _____
- Dial 1
- Press **Speaker**

Note: A LOG key may be assigned in system programming to log/off from the ACD/UCD group. A lit led indicates that the station is logged-on.

Log Off

- Press **Speaker**
- Dial access code _____
- Dial 2
- Press **Speaker**

Break Mode

Set

- Press **Speaker**
- Dial 40
- Press **Speaker**

Cancel

- Press **Speaker**
- Dial 42
- Press **Speaker**

Note 1: Break Mode is only available while an agent is logged-on.

Note 2: A Break key may be assigned in system programming to set/cancel Break Mode. A lit LED indicates that the station is in Break Mode.

Answering Call Using Headset

- Press **HEADSET** key to answer
- Converse
- Press **HEADSET** key to hang up

Volume Control

Off-Hook Ringing Volume

- Lift handset
- Dial **60**
- Dial Off-Hook Ringing
Volume code 1
- Press **Λ** or **∇** to set level
- Replace handset

Note 1: Press **Λ** or **∇** during audible telephone activity to adjust handset or speaker volume.

Note 2: When the telephone is idle, **Λ** or **∇** is used to adjust display contrast.

Ringing Volume

- Press Speaker
- Dial **60**
- Dial Ringing Volume code 1
- Press **Λ** or **∇** to set level
- Press Speaker

Programming

Resetting Feature LED

- Press **Feature**
- Dial **99**
- Press **Feature**

Note: Resetting the Feature LED will cancel Call Forward All Calls, Do Not Disturb and Callback Request settings.

Station Speed Dial

- Press **Feature**
- Press **Redial**
- Dial Speed Dial Memory location:
80-99 (in 100 Speed Dial Mode), or
***, 00-09** (in 1000 Speed Dial Mode)
- Dial trunk access code i.e. **0** (if necessary)
- Dial telephone number to be stored (24 digits maximum)
- Press **Hold** (if entering name) and dial name of party
(13 letters maximum)
- Press **Feature**

Note 1: Press **Redial** to insert a pause or **Recall** to store a hookflash.

Note 2: Refer to **Speed Dial Name** and **Station Name Input** when entering name of party.

Feature Access Keys

Station Speed Dial (Outside Numbers)

- Press **Feature**
- Press **Redial**
- Press **Feature Access Key** to be programmed
- Dial **0**
- Dial trunk access code i.e **0** (if necessary)
- Dial telephone number to be stored (16 digits maximum)
- Press **Feature**

Note 1: Press **Redial** to insert a pause and **Recall** to insert a hookflash.

Note 2: Busy Lamp Field status indication will be provided on keys programmed for DSS.

DSS/BLF (Stations) And Feature Access

- Press **Feature**
- Press **Redial**
- Press **Feature Access Key** to be programmed
- Dial **1** and station number to be stored
- OR** dial feature access code to be stored as indicated in the **Quick Entry Guide**
- Press **Feature**

One Touch Keys

Station Speed Dial (Outside Numbers)

- Press **Feature**
- Press **Redial**
- Press **One Touch Key** to be programmed
- Dial **0**
- Dial trunk access code i.e **0** (if necessary)
- Dial telephone number to be stored (16 digits maximum)
- Press **Feature**

Note 1: Press **Redial** to insert a pause and **Recall** to insert a hookflash.

Note 2: Busy Lamp Field status indication will be provided on keys programmed for DSS.

DSS/BLF (Stations) And Feature Access

- Press **Feature**
- Press **Redial**
- Press **One Touch Key** to be programmed
- Dial **1** and station number to be stored
- OR** dial feature access code to be stored as indicated in the **Quick Entry Guide**
- Press **Feature**

Station Name

While phone is idle:

- Press **Feature**
- Dial **25**
- Enter Name using keypad
- Press **Feature**

Attendant

While phone is idle:

- Press **Feature**
- Dial **25**
- Enter Station number
- Enter Name using keypad
- Press **Feature**

Note 1: Refer to Speed Dial Name and Station Name Input table.

Speed Dial Name and Station Name Input

To add a name to each speed dial entry, press the dial pad number corresponding to the alpha character desired.

i.e 2 = A,B,D,a,b,c, or 2

3 = D, E, F, d, e, f, or 3

4 = G, H, I, g, h, i, or 4

For the name Bob press: **2-2-6-6-2-2**

Key Press														
Key	1st	2nd	3rd	4th	5th	6th	7th	8th	9th	10th	11th	12th	13th	14th
1	1	@	[¥]	^	_	'	{		}	ä	â	Back to 1
2	A	B	C	a	b	c	2	Back to A						
3	D	E	F	d	e	f	3	Back to D						
4	G	H	I	g	h	i	4	Back to G						
5	J	K	L	j	k	l	5	Back to J						
6	M	N	O	m	n	o	6	Back to M						
7	P	Q	R	S	p	q	r	s	7	Back to P				
8	T	U	V	t	u	v	8	Back to T						
9	W	X	Y	Z	w	x	y	z	9	Back to W				
0	0	!	"	#	\$	%	&	'	()	Back to 0			
*	*	+	,	-	.	/	:	;	<	=	>	?	Back to *	
#	Set	Space	Back to Set											
Conf	Clear and back 1 character before cursor													

Quick Entry Guide For Programming Feature Access Keys and One Touch Keys

Feature	Press
Microphone On/Off	# ► 1
Call Forward All Set	# ► 60 ► Dial destination ► Answer ► Feature ► Feature
Call Forward Busy/ No Answer - Set	1 ► 43 ► Dial Destination ► Answer ► Speaker ► Feature
Do Not Disturb - Set	# ► 60 ► Answer ► Feature ► Feature
Call Forward All/DND - Cancel	# ► 69 ► Answer ► Feature ► Feature
Save & Repeat - Set	# ► 9
Store & Repeat - Set	# ► 7
Whisper Page	# ► 65
Quick Transfer To Voicemail	# ► 86
Background Music	# ► 26
Voice Over Originate	1 ► 6
Internal Paging All Zone	1 ► 51
Internal Paging Meet-Me	1 ► 5*
External Paging All Zone	1 ► 55
External Paging Meet-Me	1 ► 5#
Call Pick Up All Calls	1 ► 68
Call Pick Up Direct	1 ► 67

Note 1: When pressed, the **Answer Key** will not appear in the display. This is normal operation.

Note 2: Other features may be programmed in addition to those listed above. Refer to the Xen IPK Digital Voicemail User Guide for features related to Voicemail.

Quick Reference Guide

Outside Calling

Outside Call	Dial 0 ► Dial Telephone Number
Last CO/PBX number redial	Redial ► Dial #
Speed Dial	Redial ► Dial 00-99 or 000-999
Save/Store & Repeat - Access	Redial ► Dial **
Trunk Queue	Receive Trunk Busy Indication ► Dial 78
Automatic Redial	Receive busy ► Speaker ► Replace Handset ► Feature ► Redial

Internal Calling

Station Call	Dial Station Number or DSS key
Automatic Callback	Reach Busy Station ► Dial 0
Callback Request	Reach Busy/No Answer Station ► Dial #
Tone Override	Reach Busy Station ► Dial *
Voice Over Originate	Reach Busy Station ► Dial 6
Quick Transfer To Voicemail	Dial station number or DSS key ► Press Message or Dial 7

With A Call In Progress

Hold	Hold
Exclusive Hold	Feature ► Hold
Transfer	Transfer ► Dial Station Number or DSS key
Quick Transfer To Voicemail	Transfer ► Dial Station Number or DSS key ► Press Message or dial 7
Conference	Conf ► Place 2nd Call ► Conf
Call Park System	SET: Transfer ► Dial 4* ► Dial 0 - 9 RETRIEVE: Dial 4 # ► Dial 0 - 9
Save & Repeat - Save	Feature ► Dial 9
Store & Repeat - Store	Feature Dial 7 ► Dial number to Store ► Feature
Whisper Page	Receive Voice Over ► Feature ► Dial 65

From The Intercom

Internal Paging	Dial 51-54 ► Page
External Paging	Dial 55-59 ► Page
Call Pickup All Calls	Dial 68
Call Pickup Direct	Dial 67 ► Dial Station Number

From An Idle Telephone

Microphone Control	Feature ► Dial 1 OR Press MIC
Call Forward All/DND	SET: Feature ► Dial 60 ► Dial Destination Station (CF/A Only) ► Feature CANCEL: Feature ► Dial 69 ► Feature
Call Forward Busy/No Answer	SET: Speaker ► Dial 43 ► Dial Destination Station ► Speaker CANCEL: Speaker ► Dial 44 ► Speaker
Feature LED Reset	Feature ► Dial 99 ► Feature

Interactive Softkey Definitions

Softkeys	Definitions
ACB	Automatic Callback
AUTO-RD	Automatic Redial Set
CBR	Callback Request
CFA	Call Forward All Set/Cancel
CFB/NA	Call Forward Busy/No Answer Set/Cancel
DND	Do Not Disturb Set/Cancel
DOWN	Scroll Down through Speed Dial
I.D.	Caller I.D. recall
MIC	Microphone Control
MORE	Next or Previous page
MUTE	Mute handset
PARK	Call Park - System
QVM	Quick Transfer to Voice Mail
RECALL	Recall Key
RING	Switch from Voice Announce to Ring
STA	Station Speed Dial Access
STEP	Step Call
SYS	System Speed Dial Access
T.O.	Tone Override
T.Q.	Trunk Queing Set
UP	Scroll Up through Speed Dial
V.O.	Voice Over Originate
VOICE	Switch from Ring to Voice Announce

Note: Interactive Softkey only appears if programmed



NEC

The material contained herein is subject to change without prior notice at the sole discretion of NEC Business Solutions Ltd.

Stock# 8502589
Version 2
DPA. March 2006

Copyright ©2003 NEC Business Solutions Ltd
Document No. NEC-8055